

Instruction Manual  
Model 4265/4265-PLUS  
Ultrasonic Cement Analyzer  
(Original Instructions)

Revision P – October 2015  
PN: 80-0005

S/N \_\_\_\_\_



Поставщик: ЗАО “ТЕХИМПОРТ”  
Адрес: 614007, г. Пермь, ул. 25 Октября 72, офис 40  
Телефон: +7 (342) 262-85-56  
Факс: +7 (342) 262-85-60  
email: [office@techimport.ru](mailto:office@techimport.ru)  
[www.techimport.ru](http://www.techimport.ru)

Copyright © 2015, by Chandler Engineering Company, LLC

All rights reserved. Reproduction or use of contents in any manner is prohibited without express permission from Chandler Engineering Company, LLC. While every precaution has been taken in the preparation of this manual, the publisher assumes no responsibility for errors or omissions. Neither is any liability assumed for damages resulting from the use of the information contained herein.

This publication contains the following trademarks and/or registered trademarks: AMETEK, CHANDLER ENGINEERING. These trademarks or registered trademarks and stylized logos are all owned by AMETEK, Inc. All other company, product and service names and logos are trademarks or service marks of their respective owners.

# Table of Contents

<b>General Information .....</b>	<b>P-1</b>
Description of Instrument .....	P-1
Features .....	P-1
Utilities Required .....	P-2
Safety Requirements .....	P-2
Specifications .....	P-3
<b>Section 1 – Installation .....</b>	<b>1-1</b>
Unpacking the Instrument .....	1-1
Re-configuration .....	1-1
Connecting Serial Power .....	1-1
<b>Section 2 – Operating Instructions .....</b>	<b>2-1</b>
Front Panel Controls .....	2-1
Air Inlet Gauge .....	2-1
Pump Pressure Adjust Regulator .....	2-1
Pump Air Pressure Gauge .....	2-1
Relief Valve .....	2-1
Relief Valve Shutoff .....	2-1
Pump Switch .....	2-2
Pump Water Valve .....	2-2
Coolant Valve .....	2-2
Pressure Release Valve .....	2-2
Cylinder Pressure Gauge .....	2-2
Temperature Controller .....	2-2
Heater Switch .....	2-2
Main Power Switch .....	2-2
Left Rear Panel .....	2-3
Data Cable Connector .....	2-3
Ref Cable Connector .....	2-3
Monitor Cable Connector .....	2-3
Top Transducer Connector .....	2-3
J Thermocouple Connector .....	2-3
Main Power Connection .....	2-3
Fuses .....	2-3
Right Rear Panel .....	2-3
Air Inlet, Pump Water Drain/Inlet .....	2-4
High Pressure Inlet (optional) .....	2-4
Operating the Instrument .....	2-4
Preparing the Sample and Cell for a Test .....	2-5
Running a test .....	2-7
Pressure Control .....	2-7
Temperature Control .....	2-7

Ending a Test.....	2-8
Cleaning the Test Cell.....	2-8
<b>Section 3 - Maintenance and Servicing .....</b>	<b>3-1</b>
Maintenance .....	3-1
Tools Required .....	3-1
Cleaning and Service Tips .....	3-1
Calibration Procedures.....	3-1
Regulator Rebuild Instructions.....	3-2
Major Disassembly .....	3-2
Bonnet Disassembly/Reassembly.....	3-3
<b>Section 4 - Troubleshooting Guide .....</b>	<b>4-1</b>
<b>Section 5 – Replacement Parts List .....</b>	<b>5-1</b>
<b>Section 6 - Drawings .....</b>	<b>6-1</b>

# General Information

## Description of Instrument

The 4265 Ultrasonic Cement Analyzer (UCA) is an instrument that measures the compressive strength of API cement under high temperature and high pressure conditions. The instrument measures the velocity of sound through the sample then relates this value to the compressive strength using proprietary algorithms.

After the internal electronics measure the acoustic transit time, the value is transmitted to the I/O board located on the rear of the autoclave. The I/O board is connected to the RS-232 serial communication port located on the rear of the PC or to another autoclave I/O board by a four-wire RS-485 communication cable.

## Features

The major features of the 4265 Ultrasonic Cement Analyzer (UCA) are listed below:

- Easy to install and use.
- Uses Chandler Model 5270 Data Acquisition System for data retrieval, analysis and storage.
- Tests stored in database may be sorted and retrieved based on user specified data base fields.
- Built-in pump and relief valve for sample pressure control.
- Optional external chiller system.

## Utilities Required

- Power: 208-240 VAC, 50/60 Hz, 10A - Heater/solenoid valves  
90 - 240 VAC, 50/60 Hz, 1A - Instrumentation power
- Water: Clean pressurizing water, 5-150 psig (.34-10.4 bar)
- Coolant: Clean water or Ethylene glycol solution
- Air: Clean, dry compressed air; 50-100 psig (345-690 kPa)
- Drain: Suitable for hot water

## Safety Requirements

*NOTE: All Chandler Engineering equipment is calibrated and tested prior to shipment.*

# Specifications

<b>Model 4265</b>	
<b>Maximum Curing Temperature:</b>	400°F (204°C)
<b>Maximum Curing Pressure:</b>	20,000 psi (138 MPa)
<b>Heater Power:</b>	2,000 Watts

### Electrical

Main Input Voltage: 208-240 VAC, 50/60 Hz, 10A  
 Instrument Input Voltage: 90-240 VAC 50/60 Hz, 1A  
 Heater Wattage: 2000 Watts

### Shipping Dimensions and Weight

	<u>Dimensions</u>		<u>Weight</u>	
	<u>in.</u>	<u>cm</u>	<u>lbs.</u>	<u>Kg</u>
Box 1	32 x 26 x 35	81 x 66 x 89	210	95.5
Box 2	30 x 23 x 22	76 x 59 x 56	180	82
Instrument Dimensions and Weight				
	<u>in.</u>	<u>cm</u>	<u>lbs.</u>	<u>Kg</u>
	21 x 18 x 19	53 x 46 x 48	130	59

### Environmental and Utility

- Environment: Indoor use, altitude up to 6562ft (2000m)
- Ambient Temperature: 60-122°F (16-50°C)
- Storage Temperature: 40-122°F (5-50°C)
- Operating Temperature Range: 32-122°F (0-50°C)
- Max Relatively Humidity: 80% RH for temperatures up to 88°F (31°C) decreasing linearly to 50% RH at 104°F (40°C)
- Compressed Air: 50-100 psi (345-690 kPa)
- Pressurizing Water: 5-150 psig (.34-10.4 bar)
- Cooling Water/EG solution: 20-80 psi (138-552 kPa)
- Drain: Suitable for hot water/steam up to 400°F (204°C)

This page is intentionally left blank.



# Section 1 – Installation

## Unpacking the Instrument

*NOTE: Check the integrity of the instrument. Verify that all parts on the packing list are received with the instrument and are not damaged. File an insurance claim with your freight carrier if damage occurred in shipment. Contact Chandler Engineering if any items on the packing list have not been received.*

## Re-configuration

1. Apply power to the instrument.
2. Make sure the instrument is connected to serial port COM1 on the host computer.
3. Turn ON the power to the instrument.
4. Each data channel on each instrument must have a separate address. The DIP switches at the rear of the instrument are used to configure the data channels. During normal operation each of the four switches must be set to the OFF position. During configuration of the address for the SGSA, temperature, or pressure channels, the DIP switches on the autoclave must be set according to the table below.

Channel Address Configuration	SW1	SW2	SW3	SW4
Normal Operation	OFF	OFF	OFF	OFF
Temperature	ON	OFF	OFF	OFF
Pressure	OFF	ON	OFF	OFF
4265 (UCA)	OFF	OFF	ON	OFF

## Connecting Serial Power

Use the configuration software (SIXBCCD.EXE) to configure the individual data channel addresses.

A basic schematic for connecting one autoclave to another is shown in the following figure.

One autoclave in each 4265 UCA system must be connected to serial port COM1 on the host computer using a standard 25 pin male to 25 pin female or 25 pin male to 9 pin female RS-232 serial cable, depending on the computer.

1-2 SECTION 1 - QUICK START

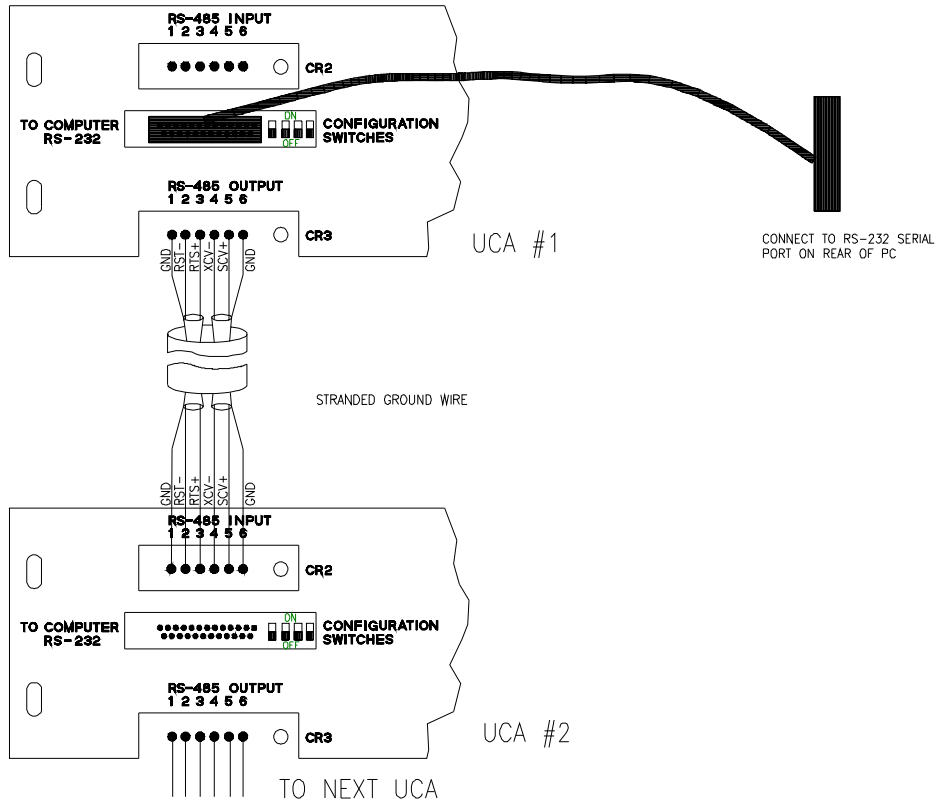

# Section 2 – Operating Instructions

## Front Panel Controls

The figure below shows the front panel and all the associated controls. The description of each control will follow the figure.

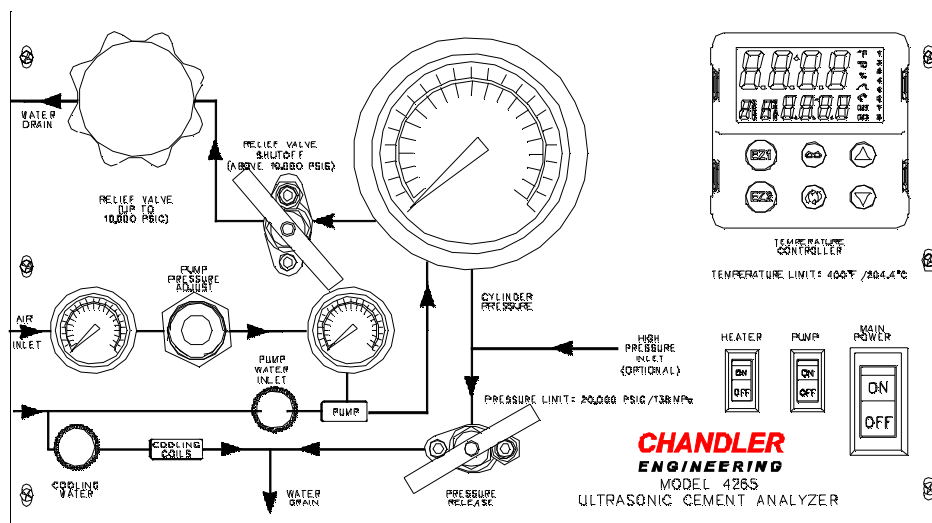

### Air Inlet Gauge

This gauge displays the pressure of the air supply connected to the autoclave. The pressure should be between 75 and 125 psig (618 and 963 kPa) when the pump is not in use.

### Pump Pressure Adjust Regulator

This regulator is used to control the pressure of the air supplied to the pump.

### Pump Air Pressure Gauge

Indicates the pressure of the air supplied to the pump. Each 5 psig (35.5 kPa) pressure applied to the pump results in approximately 1000 psig (7000 kPa) hydraulic pressure output from the pump.

### Relief Valve

The relief valve or back pressure regulator may be used to set the upper limit on the system pressure up to 10,000 psig (69,050 kPa). Turn the relief valve knob clockwise to increase pressure and counterclockwise to reduce pressure. The use of the pump and relief valve to control pressure automatically will be discussed in the section titled *Running a Test*.

### Relief Valve Shutoff

The relief valve is only usable up to pressures of 10,000 psig. If it is necessary to operate the autoclave at pressures above 10,000 psig, The RELIEF VALVE SHUTOFF must be turned clockwise to the closed position.

*Note: Closing the relief valve shutoff valve will also isolate the internal pressure transducer. The pressure transducer will not measure pressures above 10,000 psig (69,050 kPa).*

**Pump Switch**

Opens or closes a solenoid valve which controls the flow of air to the pump. Turning this switch to the ON position causes the pump to increase pressure in the test cell. Turning the switch to the OFF position stops the pump from operating.

**Pump Water Valve**

This valve is used to control the flow of water to the pump and test cell. This valve must be OFF any time the test cell is not installed. This valve must be ON to fill the tubing connected to the test cell with water or to operate the pump.

**Coolant Valve**

Used to control the flow of coolant to the heating/cooling jacket. This valve must be OFF during a test, but should be opened following a test to cool the heater and test cell.

**Pressure Release Valve**

Used to manually release pressure from the test cell. Valve must be closed during testing except when it is necessary to manually release pressure. Valve must also be closed when removing test cell with cooling water ON or else a significant water leak will occur.

**Cylinder Pressure Gauge**

Displays the pressure inside the test cell.

**Temperature Controller**

Used to control the temperature in the test cell.

**Heater Switch**

Used to turn the flow of current to the heater ON or OFF. Switch must be in the ON position during testing and should be in the OFF position as a safety precaution at other times.

**Main Power Switch**

Used to turn the 220VAC power to the heater and internal solenoid valves instrument ON or OFF. Switch must be in the ON position during testing.

## Left Rear Panel

The left rear panel contains all the connections for the cables that connect the autoclave to the processor. This panel also contains connections for the top transducer, the thermocouple, the main power, and the fuses.

### **Data Cable Connector**

This connection is not used on the 4265 Autoclave.

### **Ref Cable Connector**

This connection is not used on the 4265 Autoclave.

### **Monitor Cable Connector**

This connector is used for monitoring the ultrasonic signals within the test cell. Normally it is not used. It may be used during system testing.

### **Top Transducer Connector**

The coaxial cable attached to the top transducer must be mated to this connector prior to beginning a test.

### **J Thermocouple Connector**

The thermocouple that is attached to the top plug must be plugged into this connector prior to the beginning of a test and any time that it is necessary for the temperature controller to operate. If the thermocouple is not connected, the temperature controller will display “---” and will not function.

### **Main Power Connection**

Located beside the fuses, it requires a twist lock plug to connect the power. The power required will be 208-240 VAC, 10A.

### **Fuses**

Instrument Power

There are two fuses (1A, 250VAC) located in the Instrument Power Receptacle. To check these fuses, remove the power cord and pry off the access panel with a small screwdriver.

## Right Rear Panel

The right rear panel contains all the connections for hydraulic and pneumatic utilities.

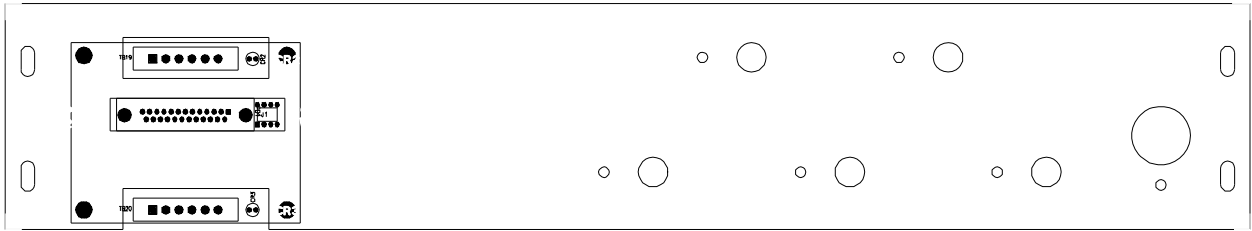

### **Air Inlet, Pump Water Drain/Inlet**

These connectors are used to connect the pneumatic and hydraulic utilities.

### **High Pressure Inlet (optional)**

This high-pressure connector exists so that pressure may be controlled with an alternate pressure control system.

## Operating the Instrument

1. Install the Model 5270 Data Acquisition Software in accordance with the instructions found in the software manual.
2. Connect power to the instrument using the cord and twist-lock connector supplied with the autoclave. It is recommended that each individual autoclave be connected to a separate circuit breaker or fuse. A 15A fuse or circuit breaker is recommended. A separate power input exists for the internal electronics. This arrangement permits the use of an uninterruptible power supply (UPS) to protect the data acquisition electronics and test data from brief power failures.

For 4265 Plus Chiller (for standard 4265, go to #5):

3. Connect the coolant to the connector labeled COOLANT IN on the rear panel of the instrument. The fitting is a 1/4-inch female NPT fitting. If water is used for cooling, the water must be clean and free of debris that could cause failure of the pump or relief valve. If in doubt, a water filter is recommended.
4. If the optional chiller is being used, connect the outlet port of the chiller system to the COOLANT IN port and the COOLANT OUT port to the chiller inlet port. Configure the chiller to operate at the minimum set point temperature (41°F, 5°C).
5. Connect the pressurizing water to the connector labeled WATER INLET on the rear panel of the instrument. The fitting is a 1/4-inch female NPT fitting. The water must be clean and free of debris that could cause failure of the pump or relief valve. If in doubt, a water filter is recommended.
6. Connect the water drain line to the connector labeled WATER DRAIN on the rear panel of the instrument.

If water is used as a coolant, the COOLANT OUT (on 4265 Plus) may also be connected to the water drain line. If an external chiller is used, the COOLANT OUT is connected to the chiller return. The fittings are 1/4-inch female NPT fittings.

The drain system must be capable of handling hot water up to 212°F (100°C) or brief surges of up to 400°F (204°C) steam for short periods of time during initial cooling of the instrument. If two or more autoclaves are connected to a common drain line, it is recommended that the common drain be 3/8-inch (10mm) inside diameter, minimum. It is also recommended that the drain system be all metal. Copper tubing with brass fittings is satisfactory.

7. Connect the air supply to the connector labeled AIR IN on the rear panel of the instrument. The fitting is a 1/4-inch female NPT fitting. The air should be dry and relatively free from dirt and oil. The air should be supplied at a pressure of 75-125 psig (618-963 kPa). Compressed nitrogen may also be used in place of the compressed air if necessary.

## Preparing the Sample and Cell for a Test

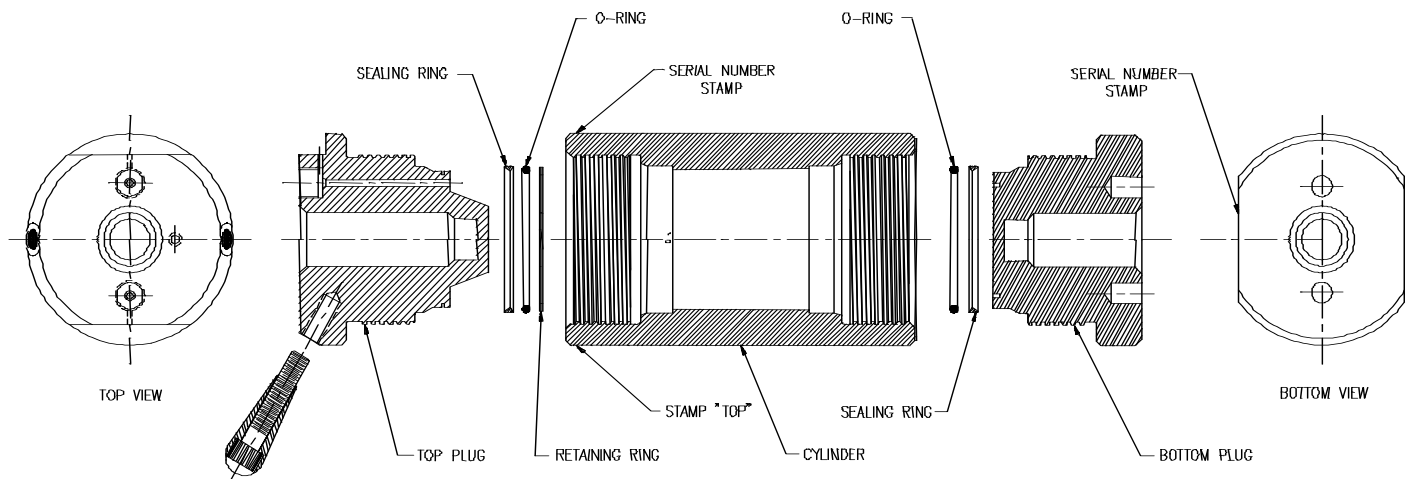

The recommended procedure for preparing the test cell and slurry for testing are outlined in the following steps:

1. Always check the sealing components to make sure they are clean and in good condition. If the O-rings are deformed or hardened replace them.
2. Apply a light coating of lithium grease to the inside cylinder and threads and also to each plug. Avoid apply grease on the flat face of the plug and base as this will affect the transducer signal. This will prevent cement from sticking to the metal and will make cleanup easier.

*Note: The test cylinder is tapered from top to bottom, with the smallest diameter at the top. This is to facilitate removal of the cement sample from the test cell. The top of the cylinder is denoted by the letter T stamped on the wrench flat on the top end of the cylinder.*

3. Place the bottom plug in a vice. Install seal ring and O-ring. Apply a thin coat of high temperature grease on the O-ring and sealing ring.

4. Screw the cylinder end marked with a “T” onto the plug that is located in the vice. It is recommended that the plug be screwed in by hand and that the plug be tightened so that it just contacts the cylinder. Further tightening after the plug has contacted the cylinder will not cause more effective sealing, and will cause plug removal difficulty.
5. Install the transducers in the top and bottom plug using the spring and transducer support plug. Always place a thin coating of high temperature ultrasonic couplant on the sensor each time it is removed. Use the couplant sparingly. Excessive buildup of couplant can lead to instrument malfunction.
6. Mix the slurry for the test in accordance with API Spec 10A procedures. Approximately 200 mL of slurry is required to fill the cell.
7. Pour approximately 200cc of cement slurry into the greased test cell. Be careful not to get cement into the threads. If cement sets up in the threads it may make plug removal and installation difficult.
8. Continue to pour cement into the test cell until level is 1/4 inch (6mm) below the circular lip in the cylinder. Use the Slurry Level Gauge to obtain the proper fill level. The slurry should touch the lower tab marked WET but not touch the upper tab marked DRY. Do not overfill the test cell or cement will be forced into the pressure and/or thermocouple ports and plug them.
9. Use a small amount of water to continue filling the cell up to the water fill line indicated on the slurry level gauge.
10. Screw the top plug into the top of the cylinder. It is recommended that the plug be screwed in by hand and that the plug be tightened so that it just contacts the cylinder. Further tightening after the plug has contacted the cylinder will not cause more effective sealing, and will cause plug removal difficulty.
11. The test cell is ready to be installed in the heating jacket.
12. Wipe the cylinder assembly clean and place in autoclave chamber.
13. Align the pressure port in the top plug with the high-pressure filter on top of the autoclave assembly. Rotate the cell clockwise to align.
14. Position the filter with the arrows (located on the side) pointing in the downward position and attach the short end of the U-tube connection to the top of the filter, as shown in the picture.
15. Attach the filter assembly into the bulkhead located on top of the instrument.
16. Connect the longer end of the tube into the top of the cylinder. Hand-tighten initially to start the threads, then use a 5/8” wrench to tighten.
17. Connect the top transducer cable to the BNC connector labeled “Top Transducer” at the back of the autoclave.
18. Install the thermocouple in the other high-pressure port in the top plug. Hand-tighten only.
19. Connect the thermocouple cable to the receptacle labeled “J Thermocouple” at the back of the autoclave.
20. Open the water supply valve until water exits the thermocouple vent hole. Tighten the thermocouple connection using a 5/8-inch wrench.

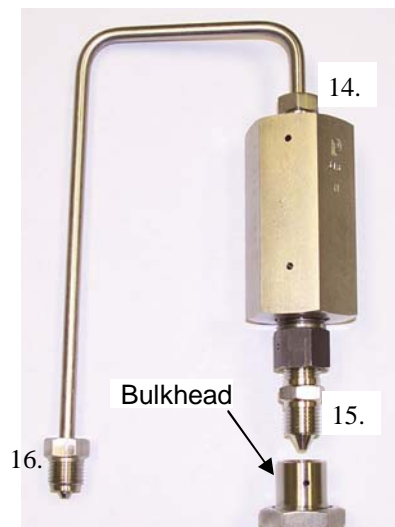

*Note: Use a rag or paper towel to catch water that exits the thermocouple vent.*



21. The test cell and autoclave are now ready to begin a compressive strength test.

## Running a test

This section describes the steps used to control pressure and temperature in the 4265 autoclave.

### **Pressure Control**

Follow the steps below to configure the pump and relief valve for automatic pressure control.

1. Make certain the test cell is installed properly, the HIGH PRESSURE INLET port on the rear of the instrument is plugged, the PUMP switch is in the OFF position, the PUMP WATER valve is turned to the ON position, and the instrument is supplied with compressed air.
2. Turn the PUMP PRESSURE ADJUST regulator clockwise until air pressure is sufficient to raise pressure to the desired pressure set point. Each 5 psig (34.5 kPa) air pressure results in approximately 1000 psig (6895 kPa) hydraulic pressure. The air pressure should not exceed 100 psig (690 kPa). Note that the pump may not be capable of achieving pressures in excess of 16,000 psig without using heat to expand the fluid and increase pressure.
3. Turn the Relief Valve knob clockwise until the release pressure is sufficient to prevent the relief valve from opening at the desired pressure set point.
4. Turn the PUMP switch to the ON position until pressure exceeds the desired set point. Turn the PUMP switch to the OFF position. Make certain the system is holding pressure before proceeding.
5. Turn the Relief Valve knob counterclockwise slowly until the test cell pressure begins to drop. Continue turning the regulator knob slowly until the pressure in the test cell equals the upper limit of the desired test pressure.
6. Turn the PUMP PRESSURE ADJUST regulator counterclockwise until the air pressure is approximately zero.
7. Turn the PUMP switch to the ON position.
8. Slowly turn the PUMP PRESSURE ADJUST regulator knob clockwise until the pump begins to stroke. Continue to slowly turn the regulator knob clockwise until the lower limit for the control pressure is achieved. Note that failure to apply any pressure to the slurry may result in a loss of transit time signal through the slurry.

### **Temperature Control**

Refer to the Chandler Temperature Controller Manual, included in the documentation package, for information on how to program and operate the temperature controller. When the controller has been programmed and the Processor is operating properly, the test may be started by turning the HEATER switch to the ON position and selecting CM.1 AUTO on the temperature controller.

1. If the chiller is being used, place the coolant switch in the AUTO position. After the cool-down segments of a temperature profile are complete, it is recommended to place the coolant switch in the OFF position to avoid possible temperature oscillations at temperatures above room temperature.
2. To end the test, turn the HEATER switch to the OFF position.

3. Turn the Temperature Controller OFF by pressing the Advance  button so that the controller displays CM.1 and pressing the up or down arrow buttons to select OFF.

*Note: Always leave the controller in the OFF mode with the HEATER switch turned OFF when the thermocouple is not installed in the cylinder.*

### **Ending a Test**

1. Open the COOLING WATER valve to cool the test cell. Monitor the test cell temperature using the Temperature Controller. Use the pump to maintain pressure on the test cell until the cell is cool. When the temperature is below 200°F (93°C) the pump switch may be turned to the OFF position and the PRESSURE RELEASE valve turned to the open position. Failure to maintain pressure at temperatures above 212°F (100°C) may cause water in the test cell to become steam.
2. Close the PUMP WATER switch.
3. Turn MAIN POWER switch OFF.
4. Close the PRESSURE RELEASE valve (clockwise). Failure to do so will result in water leakage when the U-tube or thermocouple is loosened.
5. Remove the U-shaped high-pressure tubing connecting the test cell to the high-pressure filter on the autoclave assembly.
6. Disconnect the top sensor cable.
7. Remove the thermocouple or disconnect the cable.
8. Lift the test cell from the autoclave assembly. Guide the bottom transducer cable through the front panel of the instrument.

### **Cleaning the Test Cell**

1. When the test cell has been cooled and removed from the autoclave, it should be cleaned according the following guidelines.
2. Place the test cell in a vice, topside up. Use the wrench flats and do not scratch or nick the cylinder or plugs.
3. Remove the top plug and pour off any standing water on the cement sample.
4. Remove the cell from the vice and replace in the vice topside down.
5. Unscrew and remove the bottom plug of the test cell.
6. Turn the cell over and drive the cement sample out of the test cell with a hammer.
7. Clean the cement and grease from the top and bottom plugs and cylinder with solvent.
8. When all traces of cement have been removed, grease the inner surfaces of the test cell, including the seal and O-rings.
9. Replace the O-rings if they were damaged during the test.
10. The instrument is now ready to run another test.

# Section 3 - Maintenance and Servicing

This chapter describes the basic maintenance that is required for the 4265 Autoclaves. A troubleshooting guide is also being provided in the event that problems occur.

## Maintenance

The 4265 Autoclave requires very little routine maintenance. Following the recommendations listed below will allow years of trouble free operation.

## Tools Required

- 5/8-inch wrench
- Teflon tape
- Screw Drivers
- Bench Vise

## Cleaning and Service Tips

1. Keep all test cell surfaces exposed to cement coated with a thin layer of grease. This reduces the chance of corrosion and prevents cement from adhering to the metal.
2. Keep cement off threads and out of the high-pressure ports on the top plug of the test cell.
3. Lubricate the threads on the test cell plugs periodically with anti-seize lubricant.
4. Thoroughly clean test cell of all cement immediately after each test.
5. Keep the sensor faces and cavities inside each test cell plug clean and flat.

## Calibration Procedures

The temperature controller may require periodic calibration after extended use. The procedures related to calibrating the controller may be found in the controller manual.

The measurement of transit time requires periodic calibration to ensure accurate measurements. The procedure is listed as follows:

1. Remove the cell from the instrument.
2. Thoroughly clean the cell in preparation for calibration.
3. Unscrew the bottom plug until the threads are approximately 1/2 engaged.
4. Insert the foam centering sleeve for the calibration bar.
5. Apply a small amount of acoustic couplant to the ends of the 3.5-inch calibration bar.
6. Insert the calibration bar into the cylinder and press against the bottom plug.

7. Screw the top plug into the cylinder until it engages the calibration bar. Hand-tighten only.
8. Install the cylinder assembly into the instrument. Connect the top transducer cable.
9. Using the Data Acquisition Software, enter the UCA calibration section and update the calibration values. The specifics related to calibrating using the software may be found in the Model 5270 software manual.

## Regulator Rebuild Instructions

Repair Kit Required: Chandler Part Number C09987

Refer to the figure at the end of this section.

Tools required:

- 5/16" Wide Screwdriver
- 1/2" Wide Screwdriver
- 1/2" Socket Wrench
- 1/2" Open End Wrench or Small Adjustable Wrench
- 1-3/4" Open End Wrench or Large Adjustable Wrench
- Needle Nose Pliers

The regulator is readily disassembled from the front panel. All disassembly can be done WITHOUT removing the regulator from the instrument.

### **Major Disassembly**

1. Ensure all pressure is released from the instrument.
2. Rotate the regulator knob (Item 159) fully counterclockwise to remove tension from the regulator assembly.
3. Remove the hole plug (Item 155) from the regulator knob using the narrow (5/16" wide screwdriver) to pry the hole plug free.
4. Unscrew the nut (Item 153) from inside the regulator knob cavity using the 1/2" socket wrench.
5. Unscrew the bonnet (Item 151) using the 1-3/4" open end wrench. The bonnet will come off as an assembly: Bonnet (Item 151), adjusting screw (Item 160), collar (Item 002), limit screw (Item 158) and load spring (Item 006).
6. Items 161 and 162 do not exist in the stainless steel design. The bonnet (Item 151) is a closed end component as shown in detail (A).
7. Remove the sensor assembly from the body (Item 001) using the needle nose pliers to grip and pull the sensor from the regulator body. A rocking motion may be required to free the sensor assembly.
8. Unscrew the seat retainer (Item 004) from the body Item (001) and remove the seat (Item 003).
9. Clean the seat retainer.
10. Replace the seat (Item 003). Place the beveled (chamfered) side of the seat facing out toward the sensor assembly stem (e.g., the seat should have the chamfer facing into the seat retainer thus the chamfer will face out when retained in the regulator body).
11. Install the seat retainer with the seat back into the body. Use a small amount of anti-seize lubricant on the seat retainer threads.

### **Bonnet Disassembly/Reassembly**

1. Remove the limit screw (Item 158) from the spring cap (Item 002).
2. Remove all components from the bonnet.
3. Clean and lubricate the bearing using a suitable lubricant.
4. Clean the spring cap and adjusting screw threads. Place a small amount of anti-seize lubricant on the threads.
5. Clean the spring.
6. Reassemble the bonnet components. Install the limit screw.
7. Set the bonnet assembly aside for later installation.

### **Sensor Disassembly / Reassembly**

1. Unscrew the spring pad (Item 105) from the sensor (Item 102) using the 1/2" open end wrench and the large 1/2" wide screwdriver. You may wish to clamp the spring pad in a vise to perform this step.

*Caution: Small parts are present within the sensor assembly. Take care not to lose the parts.*

2. Pull the spring pad away from the sensor. Retain the spacer (Item 106) for later use.
3. Remove the sensor components: Valve Stem (Item 101), Spring (Item 104), Spacer (Item 106), Seal (Item 007) and Sensor backup (Item 103).
4. Remove and replace the backup rings and o-rings (Items 051, 053, 052 and 054) using the new seals from the rebuild kit. Lubricate the o-rings with a suitable lubricant.
5. Replace the sensor internal components using the new internal components; Valve Stem (Item 101), Spring (Item 104) and Seal (Item 007). Reuse and reinstall the original spacer (Item 106).
6. Reassemble the sensor pad, sensor backup and sensor. Place a small amount of anti-seize lubricant on the threads.
7. Discard all the used components.

### **Major Assembly**

1. Place the sensor assembly back into the body (Item 001). Place a small amount of o-ring lubricant on the o-ring (Item 0052). Push the assembly into place using the needle nose pliers.
2. Screw the bonnet assembly with the spring into the body. Place a small amount of anti-seize lubricant on the threads.
3. Install the knob, nut and cover plug back on the regulator.

3-4 SECTION 3 – MAINTENANCE AND SERVICING

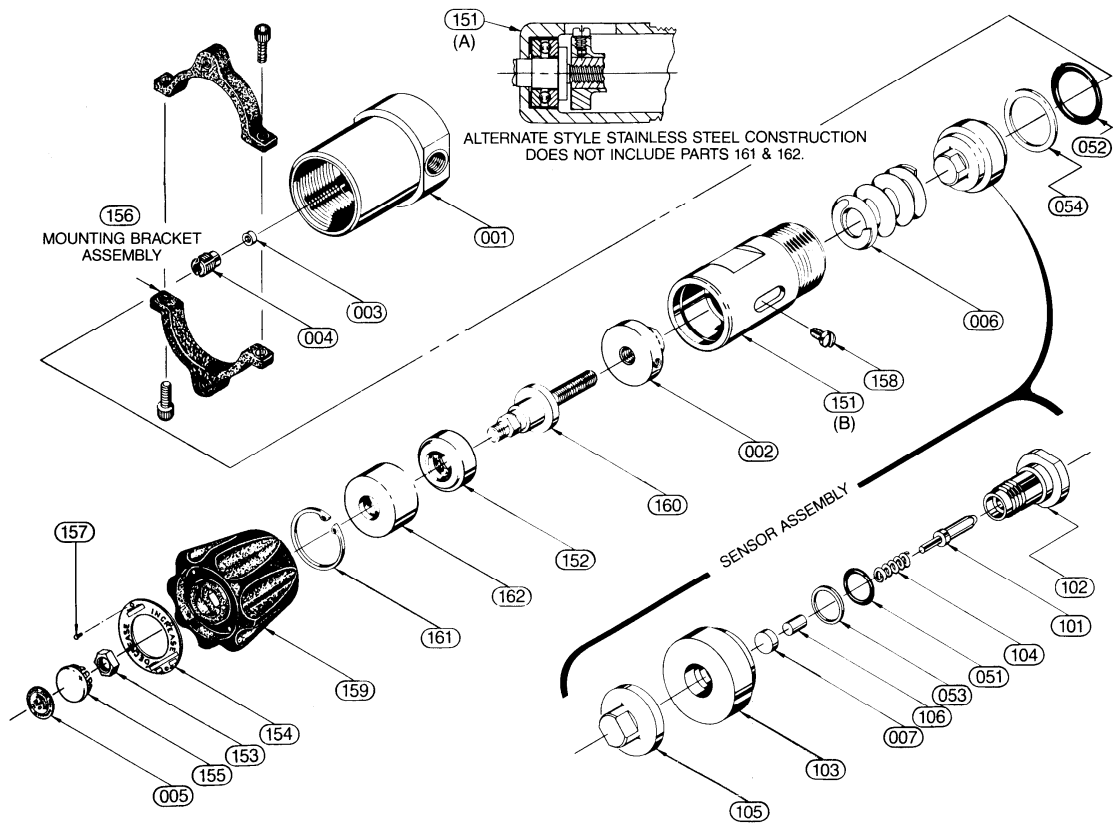

## Section 4 - Troubleshooting Guide

The following table lists symptoms of several common problems, the possible cause of the problem, and the possible solution to the problem.

Symptom	Possible Cause	Possible Solution
MAIN POWER circuit breaker switch trips off.	Short circuit in system wiring.	Disconnect power to instrument and check for short circuits with an ohmmeter.
	Faulty MAIN POWER switch.	Replace switch.
Instrument not receiving power.	Instrument not plugged in.	Connect instrument to the correct power source.
	Blown fuse or thrown breaker on circuit supplying power to the autoclave.	Check fuses and breakers on electrical supply circuit.
Pump will not operate.	Insufficient air pressure to pump.	Check air supply and make certain instrument is supplied with air between 75 and 125 psig. Check air lines for blockage. Adjust PUMP PRESSURE ADJUST regulator to a higher pressure.
	Solenoid valve controlling flow of air to pump is not functioning.	If no solenoid click is heard when the PUMP switch is turned to the ON position, a faulty solenoid valve is likely.
Pump operates, but will not build pressure.	PUMP WATER INLET valve is not open or water is not being supplied to the instrument.	Open PUMP WATER INLET valve and check flow of water to the instrument.
	High-pressure tubing or test cell has air in it.	Crack high-pressure thermocouple fitting and release any air trapped in the lines or cylinder.
	High-pressure tubing or test cell is leaking.	Check for water leakage and isolate leak.
	PRESSURE RELEASE valve not closed or is leaking.	Close valve or replace stem/seat, if necessary.

Symptom	Possible Cause	Possible Solution
(Cont.) Pump operates, but will not build pressure.	Relief valve is not holding pressure.	Turn Relief valve knob clockwise.
	Relief valve is not holding pressure.	Debris may be trapped under relief valve seat. Turn relief valve knob counterclockwise all the way and turn pump ON for a few seconds to flush the debris off the seat.
	High-pressure tubing blocked by cement.	Release pressure and clear tubing.
Large amounts of water leak from the pressure or thermocouple ports in the test cell when fittings are removed.	PUMP WATER INLET valve is open or PRESSURE RELEASE valve is open while COOLING WATER is ON.	Close PUMP WATER INLET valve and/or PRESSURE RELEASE valve.
Temperature will not rise above ambient.	Blown fuse on instrument power receptacle.	Replace fuse with 1A fuse.
	HEATER switch not in the ON position.	Turn heater switch to ON position.
Temperature overshoots the soak value.	Temperature controller PROPORTIONAL BAND tuning parameter too low.	Increase proportional band using temperature controller tune loop.
	Temperature controller INTEGRAL TIME tuning parameter too high.	Increase the integral time using the temperature controller tune loop.
Measured parameters display zero when they should not.	Loose wiring.	Find and repair loose connections.
Measured parameters display zero when they should not.	Incorrect or missing I/O module address in software.	Use the SCAN.EXE software to map each I/O channel and make certain the software is configured to agree with the existing addresses.
Measured parameters display zero when they should not. (Cont.)	Two I/O channels have the same address.	Use the SCAN.EXE software to configure each I/O channel to have a unique address.



<b>Symptom</b>	<b>Possible Cause</b>	<b>Possible Solution</b>
Transit time appears to be too small in the early portion of a test (<10 microsec/in)	Sensor may have excess couplant buildup.	Clean sensors and sensor cavities.
	Sensor may have debris under it.	Clean sensors and sensor cavities.

This page is intentionally left blank.

## Section 5 – Replacement Parts List

The following table contains a list of spare parts for the Chandler 4265 Autoclaves.

Part Number	Description
7050-4265-E	Controller, Temperature, °F
7050-4265-M	Controller, Temperature, °C
80-0010	Pressure Vessel Assembly
80-0016	Sealing Ring
80-0019	Handle, Top Plug
80-0021	Thermocouple, Type J, 20000 psig
80-0022	Heating/Cooling Jacket, 2000 W, 50/60 Hz
80-0023	Heating Jacket Mounting Stand
80-0024	Heating Jacket End Gasket
80-0025	Heating Jacket Bottom Gasket
80-0026	Heating Jacket Centering Ring
80-0031	Anti-Rotation Bracket
80-0033	Slurry Level Gauge
80-0035	Foam Centering Sleeve
80-0050	Cable Assembly, Top & Bottom Transducer
80-0057	Calibration Bar - 3.500
C05458	Fuse, 3/4A
C05596	Quick Connect, Female
C06572	Gauge, Pressure, 100 psig
C06685	Switch, Toggle, DPST
C08439	Computer Cable, 25P - 25S
C08564	Retaining Ring
C08565	O-ring, Viton
C08566	Screw, Hex Socket Head, 3/8-16 UNC x 2.00, Grade 8
C08570	Spring, Heater Support
C08571	Couplant, High Temp, 2 oz
C08572	Thermostat, 420 Open/380 Close
C08581	Relief valve
C08582	Bulkhead Fitting, 1/4 HPT-1/4 HPT
C08584	Sensor, Ultrasonic, High Temp
C08585	Fuse Holder
C08597	Quick Connect, Male
C08606	Adapter, BNC, Male-Male
C08725	Computer Cable, 25P - 9S

**5-2 SECTION 5 – REPLACEMENT PARTS LIST**

---

<b>Part Number</b>	<b>Description</b>
C08985	Spring, Compression
C09260	Kit, Pump Rebuild, Air Section
C09263	Kit, Pump Rebuild, Hydraulic Section
C09377	Pump
C09891	Filter, In-line, 60 Micron
C11293	Gauge, Pressure, 30,000 psi
P-1075	Filter Assembly, HP
P-2189	Valve, Angle, 60,000 psig
P-2197	Valve, 2-way, 30,000 psig
P-2610	Fuse, 1/4 A, 250 V, MDL-1/4
P-3107	Solenoid Valve, 220V
P-3359	Inlet, Electrical, 20 A, 250 VAC
P-3388	Switch, ON/OFF Circuit Breaker, 10A

## Section 6 - Drawings

<b>Drawing</b>	<b>Description</b>
80-0004	Interconnect Wiring Diagram
80-0006	Piping Schematic
80-0007	Wiring Diagram
80-0009	Piping Schematic, 4265 w/Halco
80-0010	Assembly, UCA Pressure Vessel
80-0046	Front Panel Layout
84-0057	High Temp Cable Assembly

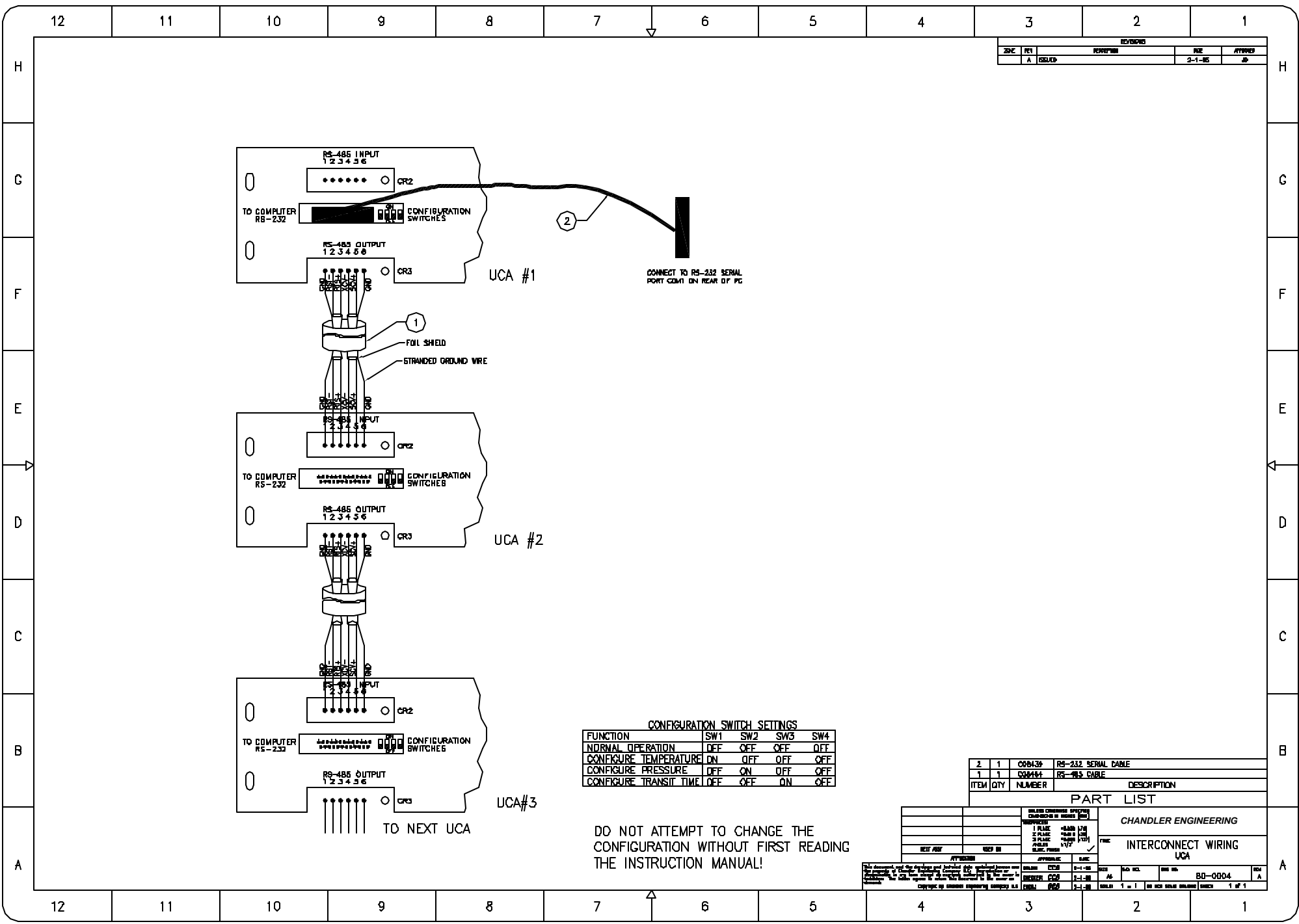

REVISIONS			
DATE	REV	DESCRIPTION	APPROVED
A	ISSUED		JP

CONNECT TO RS-232 SERIAL PORT COM1 ON REAR OF PC

**CONFIGURATION SWITCH SETTINGS**

FUNCTION	SW1	SW2	SW3	SW4
NDRNAL OPERATION	DEF	OFF	OFF	OFF
CONFIGURE TEMPERATURE	DN	OFF	OFF	OFF
CONFIGURE PRESSURE	DEF	ON	OFF	OFF
CONFIGURE TRANSIT TIME	DEF	OFF	ON	OFF

DO NOT ATTEMPT TO CHANGE THE CONFIGURATION WITHOUT FIRST READING THE INSTRUCTION MANUAL!

ITEM	QTY	NUMBER	DESCRIPTION
2	1	COM436	RS-232 SERIAL CABLE
1	1	COM437	RS-485 CABLE

**PART LIST**

ITEM		DESCRIPTION		QUANTITY		REVISIONS	
1	1	COM436	RS-232 SERIAL CABLE	1	1	1	1
1	1	COM437	RS-485 CABLE	1	1	1	1

**CHANDLER ENGINEERING**  
INTERCONNECT WIRING  
UCA

DATE	REV	BY	CHKD	APP'D	DATE	REV	BY	CHKD	APP'D	DATE	REV	BY	CHKD	APP'D

REVISIONS				
ZONE	REV	DESCRIPTION OF REVISION	DATE	APPROVALS
	Y	ECN T3056, UPDATE	6/11/10	SS TC
	Z	ECN T6351; CHG TUBES SET TUBES TO NUMBERS	1/13/15	TC TC

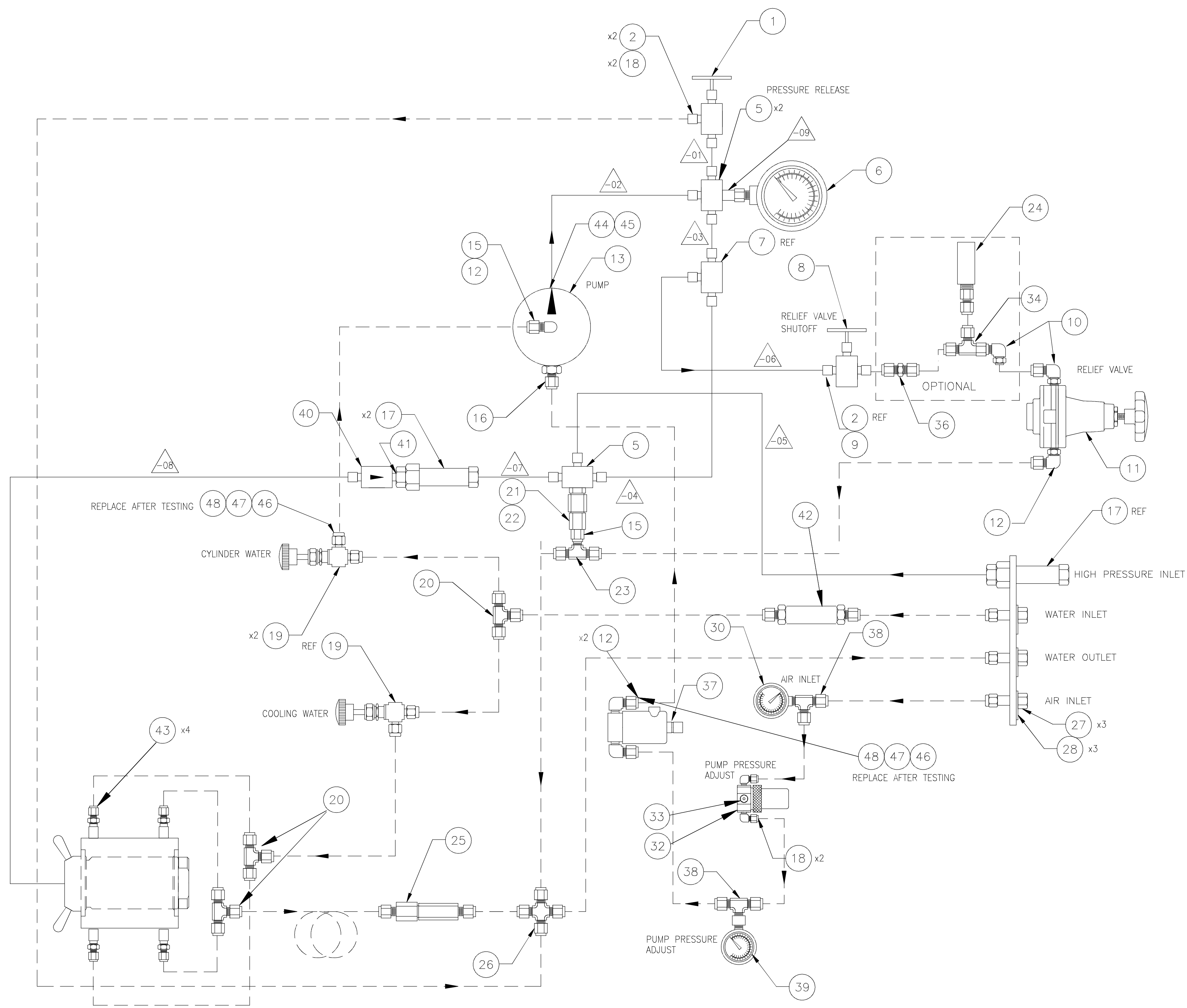

- - - - - R-645 SST TUBING (1/8)  
 \_\_\_\_\_ R-484 SST TUBING (1/4)  
 - - - - - R-125 COPPER TUBING

QTY.	REQD.	PART NUMBER	DESCRIPTION	MATERIAL SPEC.	ITEM
		2	70603-63	FER,BRS,BACK,1/4T,SW	48
		2	70603-62	FER,BRS,FR,1/4T,SW	47
		2	70603-60	NUT,HEX,BR,7/16,SW	46
		1	P-0855	COLLAR,SS,1/4-28LHX3/8LGX3/80D	45
		1	P-0193	GLAND,SST,TUBE,1/4TX9/16-18RH	44
		4	C08108	REDUCER,BRS,1/4Tx1/2T,SW	43
		1	C09891	FILTER, INLINE,60 MICRON	42
		1	C08702	ADAPT,SS,1/4MHPTX1/4MHPT,HIP	41
		1	P-1075	FILTER,ASSY SST 1/4 HPT	40
		1	C06572	PG, 100 PSI, 1-1/2, 1/8 MP, CB	39
		2	P-1274	TEE,BRS,RUN,1/8FPX1/4TX1/4T	38
		1	P-3107	VAL,SOL,MN,1/4FP,.09370RF,230V	37
		1	187-20475	CONN,BRS,1/4MPX1/8T,CR	36
					35
		1	188-02155	TEE,SS,UN,1/4FPX1/4FPX1/4FP	34
		1	P-1419	REG,PRESS,300/100 PSI,1/8 FP	33
		1	P-1887	REG,PRESS,300/100 PSI,1/8 FP	32
					31
		1	C07946	PG, 160 PSI, 1-1/2, 1/8 MP, CB	30
					29
		3	C08268	RETANR,SST,3/4ID,BHD,SW	28
		3	P-1954	CONN,BRS,1/4FPX1/4T,BHD,SW	27
		1	P-1277	CROSS,BRS,UN,1/4T,SW	26
		1	P-2980	VALVE,CHK 3000PSI SST 1/4	25
		1	C08970	XDCR,PRESS,10K PSI,1-3V OUT,1%	24
		1	P-2270	TEE,BRS,BR,1/4TX1/4TX1/4MPT	23
		1	C08590	DISK,RUPT,1/4",22,500 PSI,INC	22
		1	P-1206	SAFTEY HEAD 1/4 HIGH PRESSURE	21
		3	P-1265	TEE,BRS,UN,1/4TX1/4TX1/4T,SW	20
		2	P-0308	VALVE,NDL BRS 1/4T X 1/4T SW	19
		2	P-1246	ELBOW,BRS,1/8MNPTX1/4T	18
		2	C08582	CONN,1/4HPTX1/4HPT,60KPSI,BHD	17
		1	P-1254	CONN,BRS, 1/4 MP x 1/4 T, SW	16
		2	P-0866	BUSHG,BRS,RDCG,1/4FPX3/8MP UB	15
					14
		1	C09377	PUMP, 1/3 HP, HYDRAULICS INT'L	13
		4	P-1255	ELBOW,BRS,1/4MPX1/4T,SW	12
		1	C08581	REG,BP,200-10KPSI,TESCOM	11
		2	187-20404	ELBOW,SS,1/8TX1/4MP,SW	10
		1	188-13044	CONN,SS,1/8MPX1/8T,SW	9
		1	P-2192	VAL,ANG SST 30000PSI 1/4HPTHIP	8
		1	P-0754	TEE,SS,1/4T,60000PSI,HIP	7
		1	C11293	GAUGE, 30,000 PSI	6
		2	P-0756	CROSS,SS,1/4T,60000PSI,HIP	5
					4
					3
		2	P-1059	ADAPT,SS,1/4HPTX1/8FP,HIP	2
		1	P-2193	VAL,SS,HP,NDL,ANG,1/4HP,30KPSI	1

NOTE:  
 △-01 THRU △-09 REFERENCES TUBE FROM 80-0042 TUBE SET.

UNLESS OTHERWISE SPECIFIED DIMENSIONS IN INCHES [mm]		<b>CHANDLER ENGINEERING</b>  TITLE: PIPING SCHEMATIC	
TOLERANCES:			
1 PLACE	+0.030	APPROVALS: _____ DATE: 4/1/97 CHECKED: JUM 4/1/97 ENGR.: JJM 4/1/97	SIZE: D S.O. NO. DWG NO. 80-0006 REV. Z
2 PLACE	+0.010		
3 PLACE	+0.005	SCALE: 1" = 1" TITLE BLOCK REV: 1.0 SHEET: 1 of 1	
ANGLES	+1/2"		
SURF. FINISH	63		

This document and the drawings and technical data contained hereon are the property of Chandler Engineering Company LLC. Reproduction or dissemination in any form except as expressly authorized by the owner is forbidden. The holder agrees to return this document to the owner on demand. Copyright by Chandler Engineering Company LLC

REVISIONS				
ZONE	REV	DESCRIPTION	DATE	APPROVED
	R	ECN T5378; CHANGE TO WATLOW CONTROLLER	6/13/13	TRB
	S	ECN T5484; CORRECTED WIRING FROM SSR TO CONTROLLER	6/14/13	TRB

- 1 USE HIGH TEMPERATURE SOLDER WITH SOLDERING IRON DEDICATED TO HIGH TEMPERATURE SOLDER. THIS IS TO PREVENT CONTAMINATION OF HIGH TEMPERATURE SOLDER WITH LOW TEMPERATURE SOLDER. COVER CONNECTIONS WITH TEFLON HEAT SHRINK TUBING.
- 2 ALL POWER WIRING TO BE TWISTED PAIRS WHERE POSSIBLE.
- 3 ALL WIRES AND ITEMS SHOWN AS DASHED LINES ARE OPTIONAL.
- 4 USE RTV SEALANT (DOW CORNING 736) ON 80-0022 (HEATER)

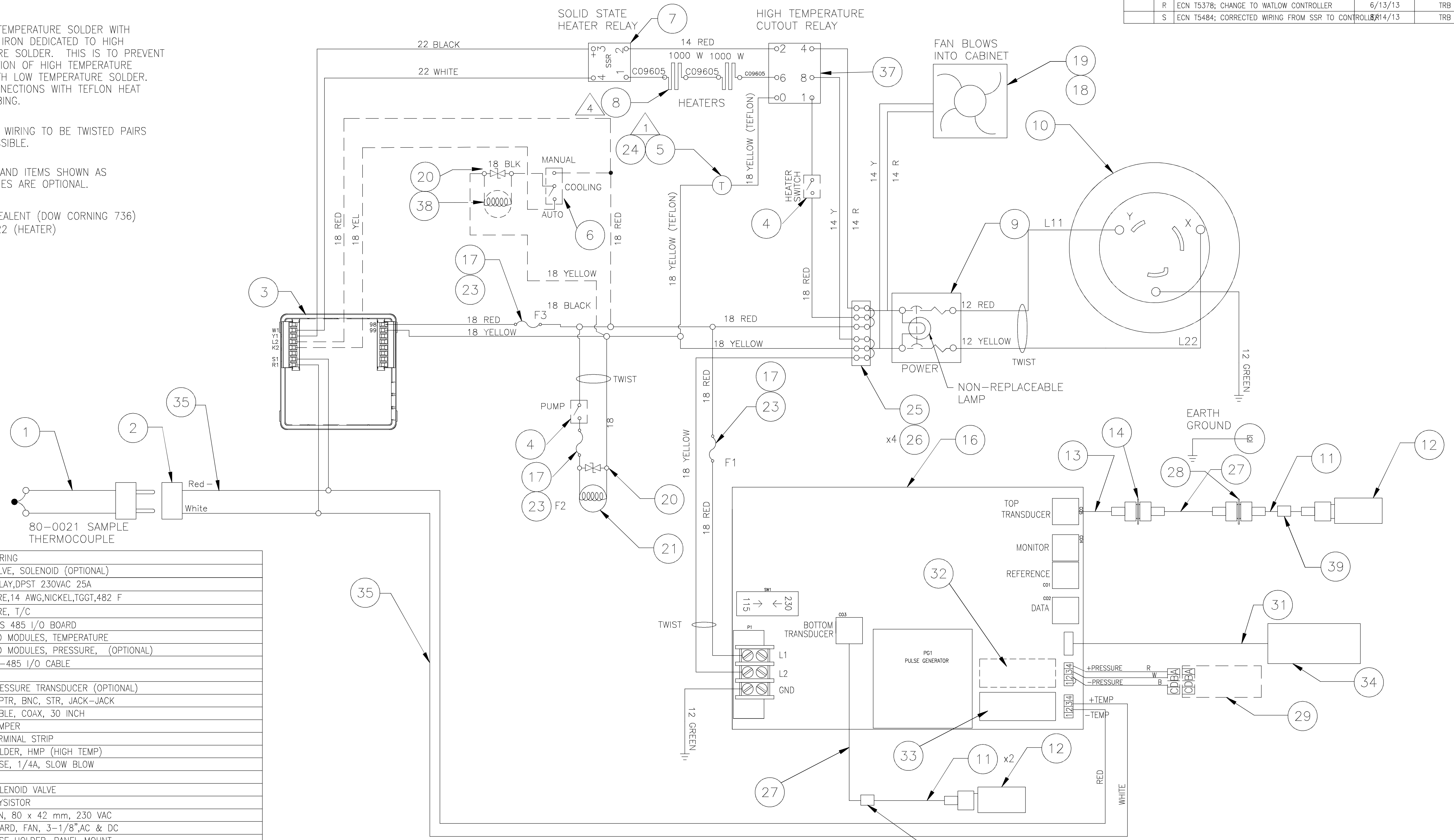

ITEM	QTY	NUMBER	DESCRIPTION
39	2	C08589	SPRING
38	1	C09163	VALVE, SOLENOID (OPTIONAL)
37	1	C08999	RELAY, DPST 230VAC 25A
36	5'	C09605	WIRE, 14 AWG, NICKEL, TGGT, 482 F
35	2'	C07251	WIRE, T/C
34	1	80-0112-01	R/S 485 I/O BOARD
33	1	C08459	I/O MODULES, TEMPERATURE
32	1	C08460	I/O MODULES, PRESSURE, (OPTIONAL)
31	1	80-0117	RS-485 I/O CABLE
30			
29	1	C08970	PRESSURE TRANSDUCER (OPTIONAL)
28	1	C08606	ADPTR, BNC, STR, JACK-JACK
27	2	80-50	CABLE, COAX, 30 INCH
26	4	P-2005	JUMPER
25	1	P-0417	TERMINAL STRIP
24	1		SOLDER, HMP (HIGH TEMP)
23	3	P-2610	FUSE, 1/4A, SLOW BLOW
21	1	P-3107	SOLENOID VALVE
20	1	C06892	THYSISTOR
19	1	C08889	FAN, 80 x 42 mm, 230 VAC
18	1	C08890	GUARD, FAN, 3-1/8", AC & DC
17	3	P-2265	FUSE HOLDER, PANEL MOUNT
16	1	80-102-02	SP PC CARD ASS'Y
15	1		
14	1	C08587	ADAPTER, BNC, BHD
13	1	80-0051	CABLE, COAXIAL, 12 INCH
12	1	C08584	TRANSDUCER, ULTRASONIC (PAIR)
11	1	84-0057	CABLE, TOP TRANSDUCER
10	1	P-3359	POWER CONNECTOR, 250V, 20A
9	1	P-3388	SWITCH, DPST, CIRCUIT BREAKER, 10A
8	1	80-0022	HEATING/COOLING JACKET
7	1	C08262	RELAY, SSR, 240VAC, 45A, CHASSIS
6	1	C08126	SWITCH, AUTO/ MAN (OPTIONAL)
5	1	C08572	THERMOSTAT, 400°F
4	2	C08106	SWITCH, ROCKER, SPST
3	1	C15678	TEMPERATURE CONTROLLER
2	1	P-2380	PANEL JACK, J THERMOCOUPLE
1	1	80-0021	THERMOCOUPLE, TYPE J

UNLESS OTHERWISE SPECIFIED DIMENSIONS IN INCHES [mm]		TOLERANCES:		TITLE	
1 PLACE +0.030 [.76]		2 PLACE +0.010 [.25]		UCA	
3 PLACE +0.005 [.127]		ANGLES 1/2°		WIRING DIAGRAM	
SURF. FINISH 32/		APPROVALS		REV.	
DRAWN: STAFF		DATE		80-0007	
CHECKED: JJM		DATE		SCALE: 1 = 1	
ENGR: JJM		DATE		TITLE BLOCK REV: 1.0	
SHEET: 1 of 1		DRAWN: STAFF		S.O. NO.	
CHECKED: JJM		DATE		DWS NO.	
ENGR: JJM		DATE		80-0007	

CHANDLER ENGINEERING

UCA WIRING DIAGRAM

SCALE: 1 = 1 TITLE BLOCK REV: 1.0 SHEET: 1 of 1

This document and the drawings and technical data contained herein are the property of Chandler Engineering Company LLC. Reproduction or dissemination in any form except as expressly authorized by the owner is forbidden. The holder agrees to return this document to the owner on demand.



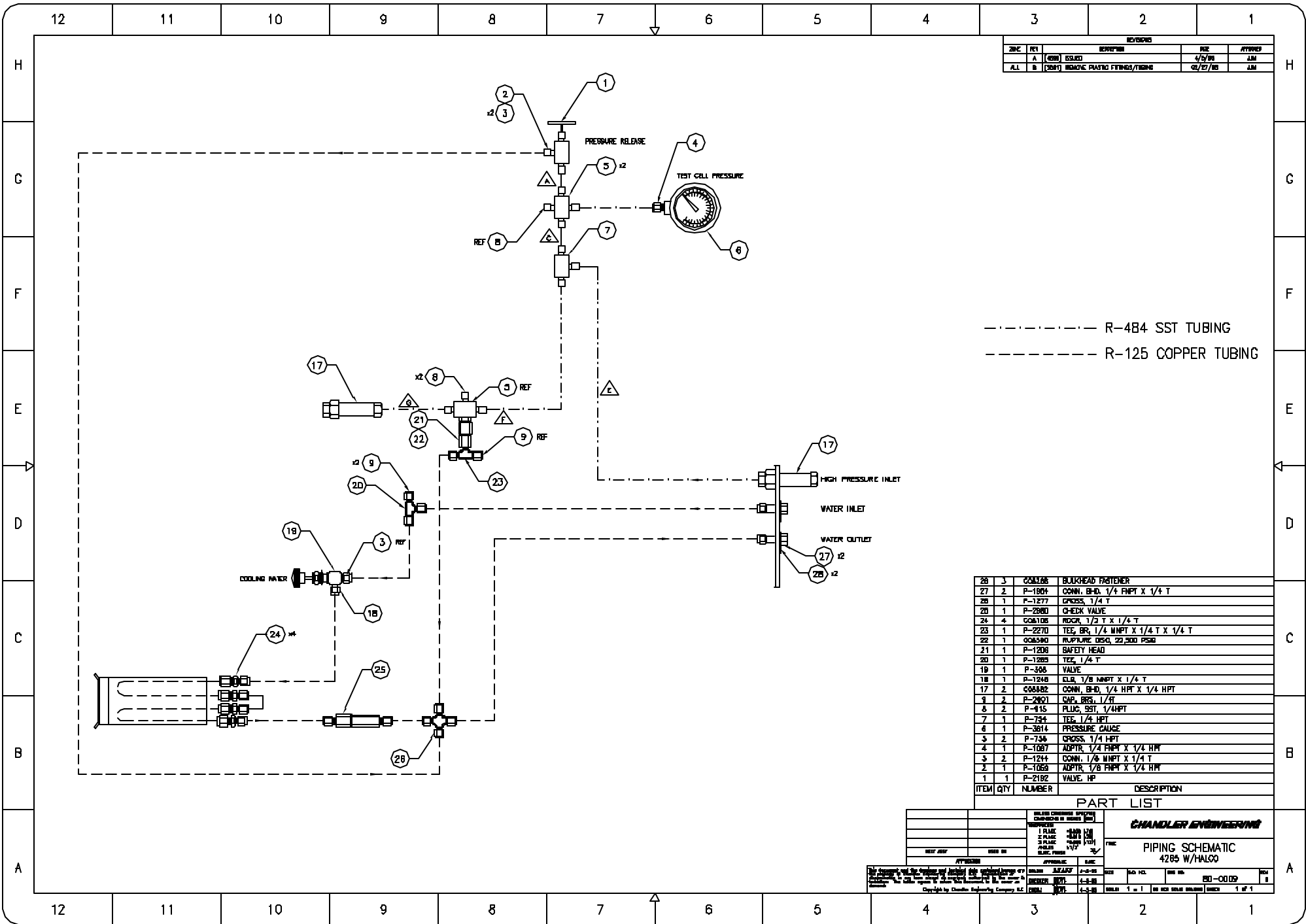

REVISIONS				
REV	BY	DESCRIPTION	DATE	APPROVED
A	AKM	ISSUED	4/9/88	JLM
ALL	B	REMOVED REMANENT PLASTIC FITTINGS/TUBING	02/27/88	JLM

- - - - - R-484 SST TUBING  
 - - - - - R-125 COPPER TUBING

ITEM	QTY	NUMBER	DESCRIPTION
28	3	CG&L06	BULKHEAD FASTENER
27	2	P-1864	CONN. BH-D, 1/4 FNPT X 1/4 T
26	1	P-1277	CROSS, 1/4 T
25	1	P-2880	CHECK VALVE
24	4	CG&L08	ROTOR, 1/2 T X 1/4 T
23	1	P-2270	TEE, BR, 1/4 MNPT X 1/4 T X 1/4 T
22	1	CG&S80	FLUPURE, 2500, 22,000 PSIG
21	1	P-1208	SAFETY HEAD
20	1	P-1285	TEE, 1/4 T
19	1	P-306	VALVE
18	1	P-1248	ELB, 1/8 MNPT X 1/4 T
17	2	CG&A82	CONN. BH-D, 1/4 HPT X 1/4 HPT
9	2	P-2807	SNP. BRG, 1/4 T
8	2	P-415	PLUG, SST, 1/4HPT
7	1	P-784	TEE, 1/4 HPT
6	1	P-3614	PRESSURE GAUGE
3	2	P-734	CROSS, 1/4 HPT
4	1	P-1087	ADPTR, 1/4 FNPT X 1/4 HPT
3	2	P-1244	CONN. 1/8 MNPT X 1/4 T
2	1	P-1089	ADPTR, 1/8 FNPT X 1/4 HPT
1	1	P-2182	VALVE, HP

PART LIST

1 PLACE 2 PLACE 3 PLACE 4 PLACE 5 PLACE		1 PLACE 2 PLACE 3 PLACE 4 PLACE 5 PLACE		1 PLACE 2 PLACE 3 PLACE 4 PLACE 5 PLACE		1 PLACE 2 PLACE 3 PLACE 4 PLACE 5 PLACE		1 PLACE 2 PLACE 3 PLACE 4 PLACE 5 PLACE		1 PLACE 2 PLACE 3 PLACE 4 PLACE 5 PLACE		1 PLACE 2 PLACE 3 PLACE 4 PLACE 5 PLACE		1 PLACE 2 PLACE 3 PLACE 4 PLACE 5 PLACE		1 PLACE 2 PLACE 3 PLACE 4 PLACE 5 PLACE		1 PLACE 2 PLACE 3 PLACE 4 PLACE 5 PLACE		1 PLACE 2 PLACE 3 PLACE 4 PLACE 5 PLACE	
<b>CHANDLER ENGINEERING</b>												<b>PIPING SCHEMATIC</b> 4285 W/HALCO				80-00109		1 OF 1			

REVISIONS				
ZONE	REV.	DESCRIPTION	DATE	APPROVED
	F	CREATE DRAWING	3/12/09	SS/TC

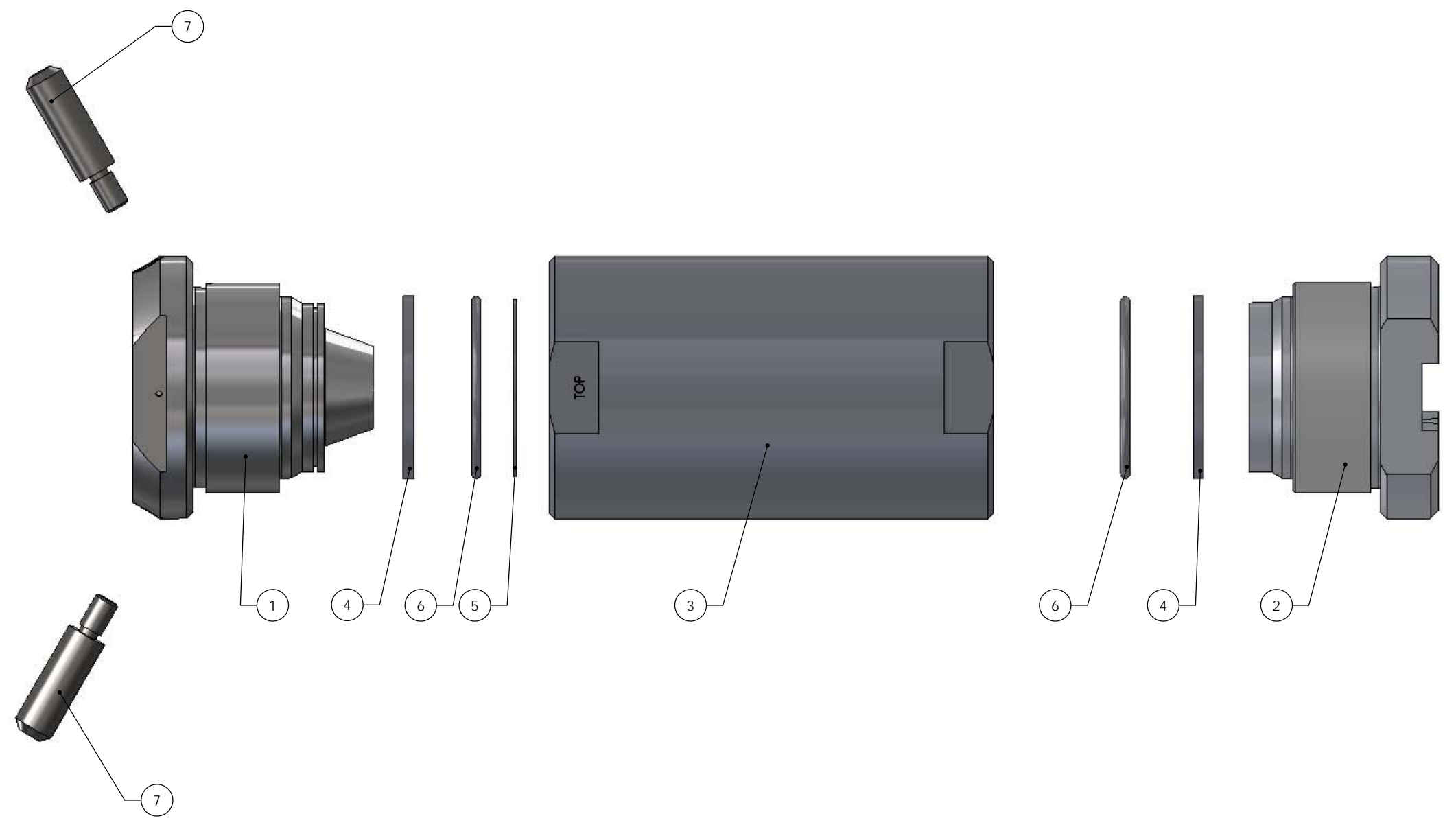

**NOTE:**

1. TOP PLUG, BOTTOM PLUG, AND CYLINDER MUST HAVE SERIAL NUMBER STAMP AFTER FINAL PRESSURE TESTING.
2. ADD LITHIUM GREASE (P-3217) TO O-RING AREA OF BOTH PLUGS PRIOR TO ASSEMBLY.
3. AFTER PRESSURE TEST IS COMPLETE, CYLINDER SHOULD BE RINSED OUT WITH SOLVENT AND WIPED DRY WITH RAG.
4. LITHIUM GREASE (P-3217) SHOULD BE RE-APPLIED TO O-RING AREA AND CYLINDER SHOULD BE RE-ASSEMBLED.
5. CYLINDERS SHOULD BE PRESSURE TESTED, THEN FUNCTIONALLY TESTED.
6. PACKAGE USING BOX C12549.

**PED CONTROLLED DRAWING**

ITEM NO.	PART NUMBER	QTY.	DESCRIPTION	MATERIAL
1	80-0011	1	PLUG, TOP, UCA/SGSA	
2	83-0013	1	PLUG, BOTTOM	
3	80-0014	1	VESSEL, PRESSURE, UCA	4340AQ
4	80-0016	2	SEAL RING - CYLINDER	4340AQ
5	C08564	1	RING, RETAINING, RS-250	316SS
6	c08565	2	ORING, VITON, AS-230-V75	VITON
7	7750-0115	2	HANDLE, PLUG, CYLINDER	SS

UNLESS OTHERWISE SPECIFIED DIMENSIONS IN INCHES		<b>CHANDLER ENGINEERING</b>	
TOLERANCES:			
1 PLACE	±0.030	TITLE ASSEMBLY, UCA PRESSURE VESSEL	
2 PLACE	±0.010		
3 PLACE	±0.005		
ANGLES	±1/2°		
SURF. FINISH		APPROVALS	
APPLICATION		DATE	
BREAK SHARP EDGES, DEBURR		DRAWN: SS 3/12/09	
NEXT ASSY		USED ON	
APPROVALS		DATE	
ENGR: . . .		SIZE D DWG NO. 80-0010 REV. F	
THIS DOCUMENT AND THE DRAWINGS AND TECHNICAL DATA CONTAINED HEREON ARE THE PROPERTY OF CHANDLER ENGINEERING COMPANY, LLC. REPRODUCTION OR DISSEMINATION IN ANY FORM EXCEPT AS EXPRESSLY AUTHORIZED BY THE OWNER IS FORBIDDEN. THE HOLDER AGREES TO RETURN THIS DOCUMENT TO THE OWNER ON DEMAND. COPYRIGHT BY CHANDLER ENGINEERING COMPANY, LLC.		SCALE: 1:8 TITLE BLOCK REV: 2.0 SHEET: 1 of 1	

REVISIONS				
ZONE	REV	DESCRIPTION	DATE	APPROVED
	D	ECN 5488	10-20-97	JJM
	F	ECN T2372; ADDED P/N's	07/01/09	AMH/TC
	G	ECN T5378; CHANGED CONTROLLER TYPE	6/13/13	TRB

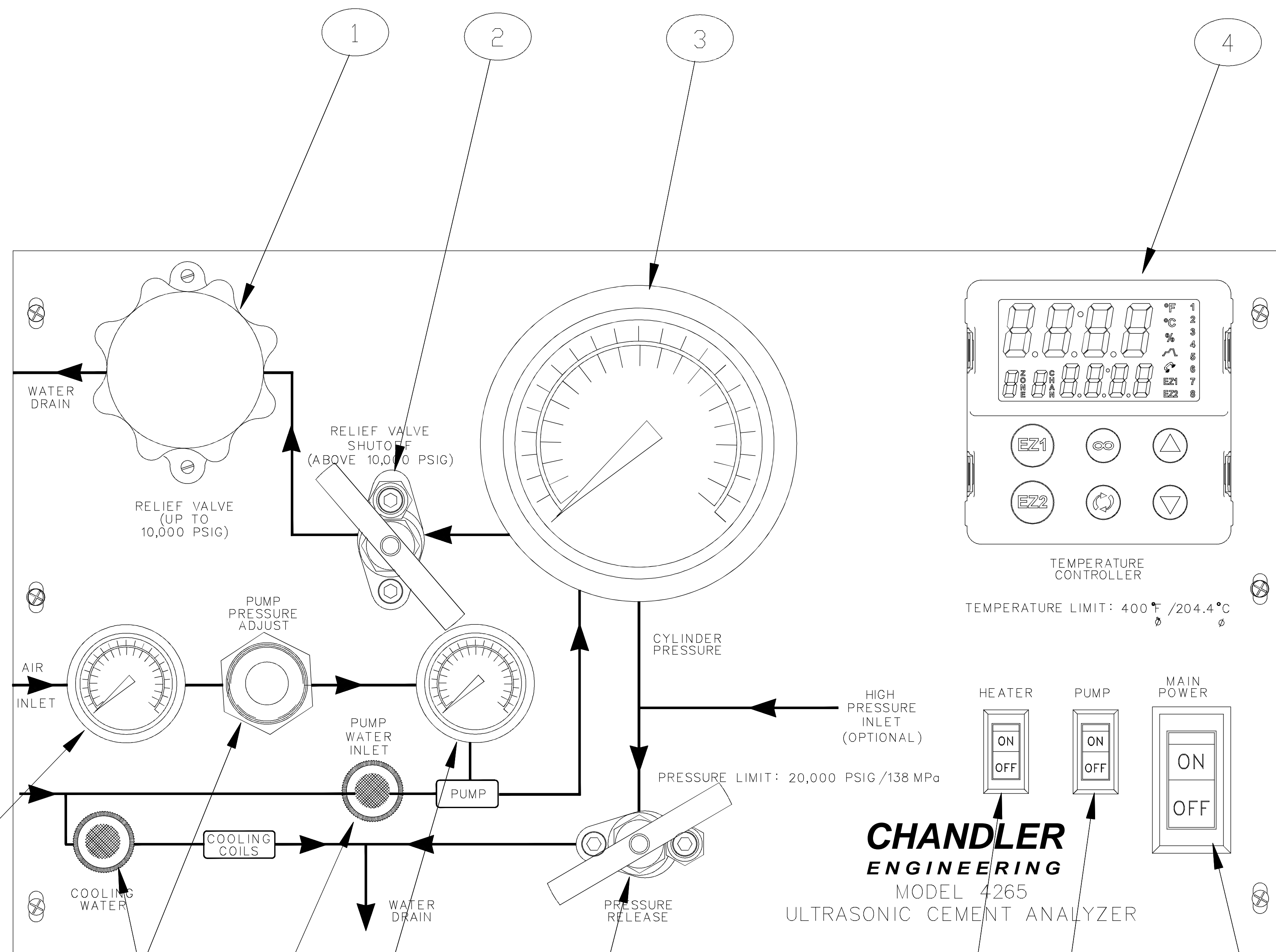

1. C08581 - RELIEF VALVE
2. P-2192 - RELIEF VALVE SHUT-OFF
3. C11293 - PRESSURE GAUGE
4. C15678 - TEMPERATURE CONTROLLER
5. C07946 - PRESSURE GAUGE
6. P-1887 - PUMP PRESSURE ADJUST
7. P-0308 - NEEDLE VALVE
8. C06572 - PUMP PRESSURE GAUGE
9. P-2193 - PRESSURE RELEASE VALVE
10. C08106 - HEATER SWITCH
11. C08106 - PUMP SWITCH
12. P-3388 - 230V POWER SWITCH

**CHANDLER**  
**ENGINEERING**  
 MODEL 4265  
 ULTRASONIC CEMENT ANALYZER

QTY.	REQD.	PART NUMBER	DESCRIPTION	MATERIAL SPEC.	ITEM
PARTS LIST					
UNLESS OTHERWISE SPECIFIED DIMENSIONS IN INCHES [mm]					
TOLERANCES:					
1 PLACE +0.030 [.76]					
2 PLACE +0.010 [.25]					
3 PLACE +0.005 [.127]					
ANGLES +1/2° 32/					
SURF. FINISH					
APPROVALS					
DRAWN: AMW		DATE: 07-27-95		S.O. NO.	
CHECKED: CCD		DATE: 07-27-95		DWG NO. 80-0046	
ENGR.: CCD		DATE: 07-27-95		SCALE: 1 = 1	
DO NOT SCALE DRAWING SHEET: 1 of 1					

This document and the drawings and technical data contained hereon are the property of Chandler Engineering Company LLC. Reproduction or dissemination in any form except as expressly authorized by the owner is forbidden. The holder agrees to return this document to the owner on demand.  
 Copyright by Chandler Engineering Company LLC

8

7

6

5

↓

4

3

2

1

F

E

D

C

B

A

F

E

D

C

B

A

REVISIONS				
ZONE	REV	DESCRIPTION	DATE	APPROVED
	A	ISSUED	3/16/99	JJM
	B	[6590] UPDATED	01/10/00	JJM
	C	[6696]; CHANGED ITEM 5	06/06/00	AMW/JH
	D	[7266]; REMOVED SPRING	02/15/01	AMW/BD

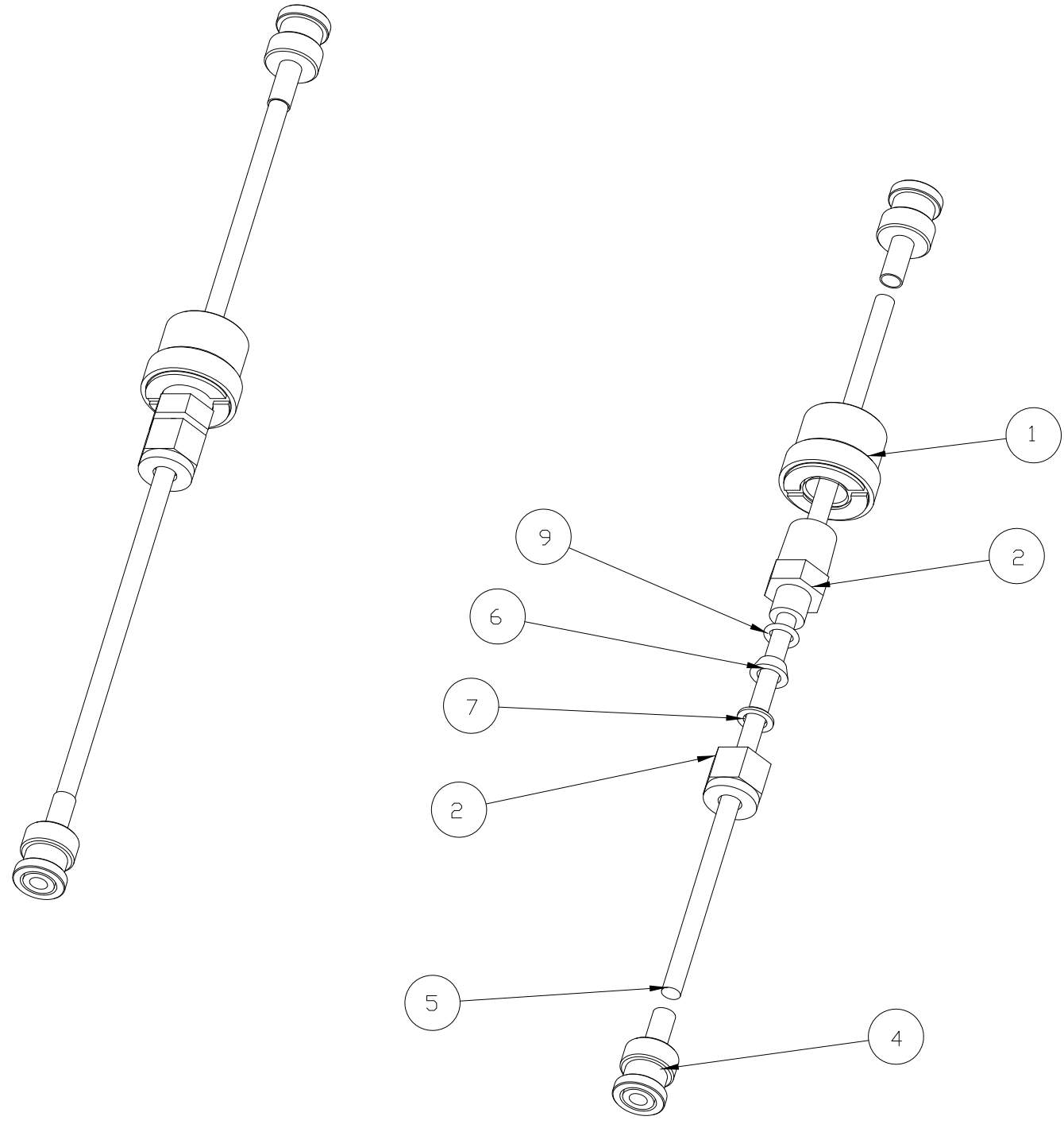

QUANTITY REQ'D	PART NUMBER	DESCRIPTION	MAT'L SPEC	ITEM
	1	P-0061	O-RING	9
				8
	1	C09033	FERRULE, BACK, TFE	7
	1	C09032	FERRULE, FRONT, TFE	6
	1	C09035	CABLE, COAXIAL, 8.5"L	5
	2	C08578	CONNECTOR, BNC	4
				3
	1	84-0061	FITTING, CABLE	2
	1	84-0027	SLEEVE, TOP CONNECTOR	1

UNLESS OTHERWISE SPECIFIED, DIMENSIONS IN INCHES [mm]		<b>CHANDLER ENGINEERING</b>	
TOLERANCES:			
.X	±0.030	TITLE ASS'Y, CABLE, HIGH TEMP	
.XX	±0.010		
.XXX	±0.005		
X°	±0.50°		
84-0045	MODEL 4262	APPROVAL	DATE
NEXT ASS'Y	USED ON	DRN: JJM	16-Mar-99
APPLICATION		CHK: JJM	16-Mar-99
This document and the drawings and technical data contained hereon are the property of Chandler Engineering Co., LLC. Reproduction or dissemination in any form except as expressly authorized by the owner is forbidden. The holder agrees to return this document to the owner on demand. Copyright by Chandler Engineering Co., LLC.		ENG: JJM	16-Mar-99
		SIZE	DWG NO.
		A2	84-0057
		SCALE: 1.000	SHEET 1 OF 1

8

7

6

5

↑

4

3

2

1